

Assembling Cedar Garden Bench

Tools needed for assembly:

Drill.

Pliers and 1/4" socket set.

Hammer for tapping bolts and screws.

Step 1. Lay out all the parts and identify them by comparing them with the drawings.

Step 2. Bolt the seat and back assemblies together with the 5-1/2" bolts. Use a small washer on each end of the bolts. Put (1) small washer on the bolt before sliding it through the back and seat. Then use another small washer on the end and add the 1/4" nut.

Step 3. Fasten the arm and leg assemblies to the seat with the 3" bolts. Put a large washer on each end of the bolts. Next, put (1) large washer on bolt then slide through the leg from the outside and then through the seat. Add the other large washer the n 1/4" nut and hand tighten. Fasten the arms to the back with the two (2) 3" carriage (smooth head) bolts. Use a small washer under the 1/4" nut only.

Step 4. Attach the stabilizer board to the front legs and up against the bottom of the seat with four (4) screws, turning it so the notches fit over the legs.

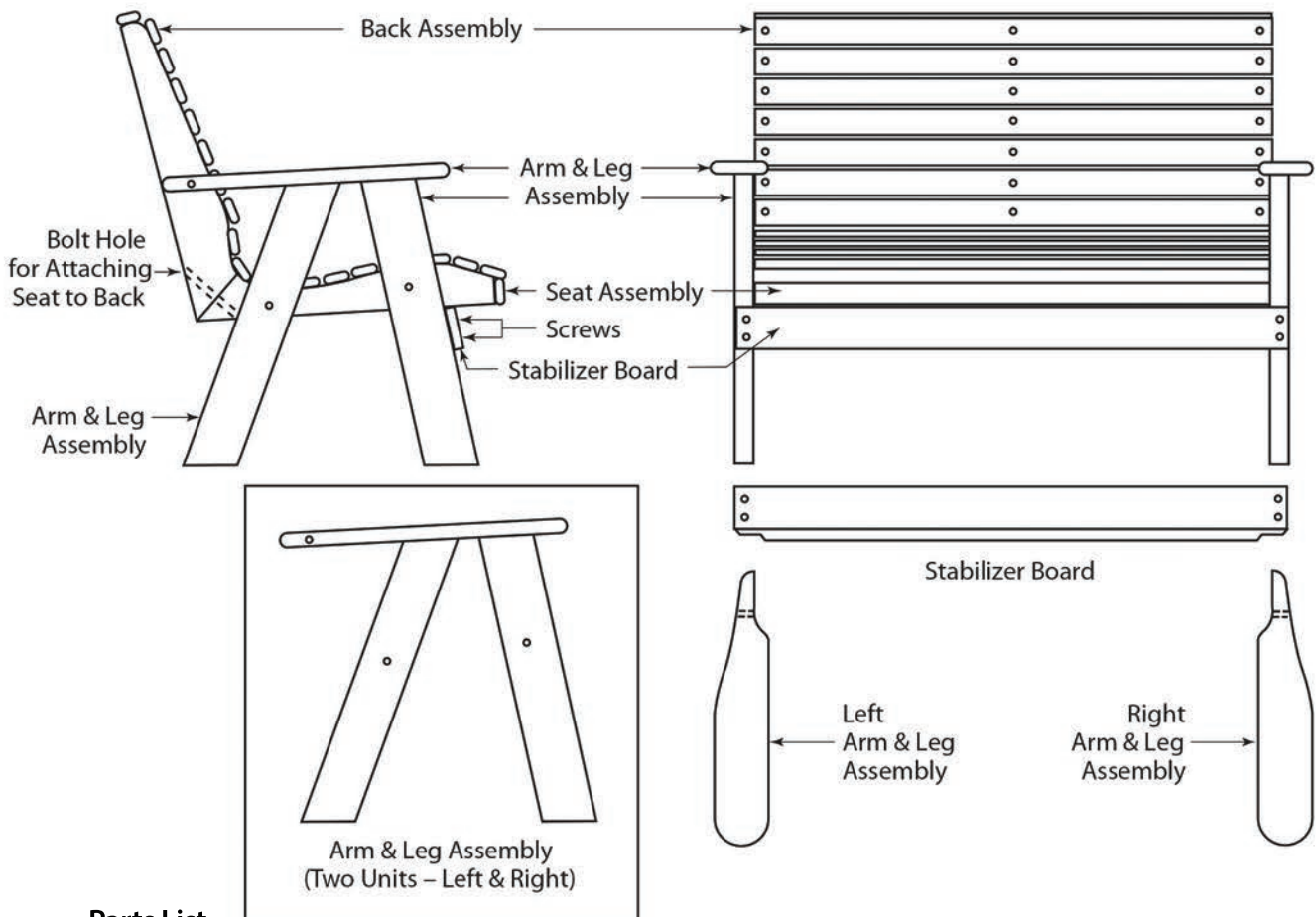

Parts List

1- Back Assembly

1- Seat Assembly

2- Arm & Leg Assemblies

1- Stabilizer Board

2- 3" Carriage Bolts

4- Hex Head Bolts

8- Large Washers

8- 2" Screws

6(2ft), 8 (4ft), 10(5 & 6ft) - Small Washers

2(2ft), 3(4ft), 4(5 & 6ft)- 5 1/2" Bolts

8(2ft), 9(4ft), 10(5 & 6ft) - 1/4" Nuts