

# Cedar Table w/ Attached Benches Assembly Instructions (4', 5', 6')

Please read through instructions entirely before beginning assembly.

## Tools Needed for Assembly

7/16" Socket  
Hammer for tapping bolts  
#2 Square Bit (Included)

## Parts List

1- Table Top Assembly  
2- Seat Assemblies  
2- Leg Assemblies  
2- 45° Braces

## Hardware List

8- 3" Bolts  
4- 2 1/2" Lag Screws  
8- 1/4" Nuts  
16 - Large Washers  
4- Small Washers

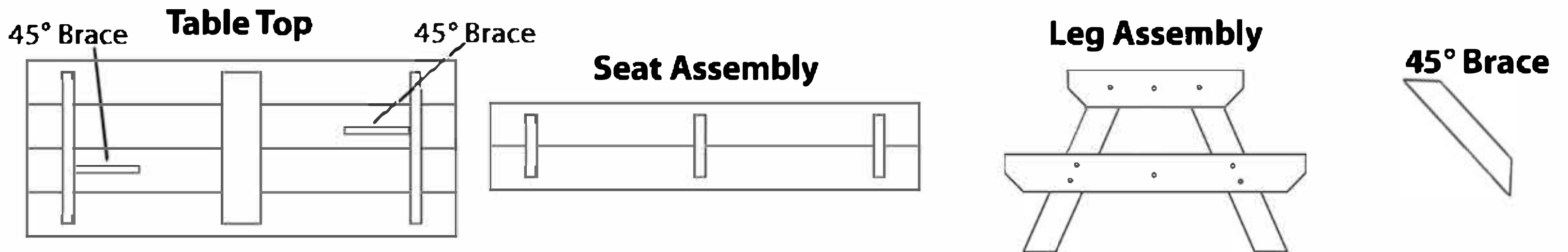

**Step 1** Lay out and identify all parts and hardware.

**Step 2** Lay the top upside down on a clean flat surface. We recommend using the box that the product was shipped in. Attach the leg assemblies onto the table top braces with four 3" bolts using a large washer under the head and nut of each bolt.

*Before putting on the leg assemblies, be sure the table and seat supports face to the outside while putting it on the **inside** of the table top brace.*

**Step 3** While the table is upside down, attach the 45° braces. Place the 45° angle of the small brace onto the table top and up against the horizontal brace of the table and seat support. Note: You will have to offset each 45° brace slightly so the brace misses the gap between the middle boards. Take 2 1/2" lag screws with a small washer and put it through each end of the 45° brace. using a hammer, lightly tap the lag screw into the table top. Note there are no pre-drilled holes for the 45° braces. We do not pre-drill for strength purposes. Then tighten with a 7/16" socket. Repeat on seat support. Do not over tighten! Repeat the same steps on the brace on the opposite end.

**Step 4** Stand the table upright. Place seat assemblies on the table and bench supports. Fasten in the same manner as the table top. Tighten all nuts. Enjoy your picnic table!

